



TRANSPORTATION CABINET

Frankfort, Kentucky 40622
www.transportation.ky.gov/

Steven L. Beshear
Governor

Michael W. Hancock, P.E.
Secretary

February 13, 2012

CALL NO. 336
CONTRACT ID NO. 122326
ADDENDUM # 1

Subject: Butler County, FE01 016 9007 034-038
Letting February 24, 2012

- (1) Revised - Special Notes Applicable to Project - Page 12-27 of 98
- (2) Deleted - Pages 28-29 of 98
- (3) Revised - Bid Items - Page 98 of 98

Proposal revisions are available at <http://transportation.ky.gov/contract/>.

If you have any questions, please contact us at 502-564-3500.

Sincerely,

A handwritten signature in blue ink that reads "Ryan Griffith".

Ryan Griffith
Director
Division of Construction Procurement

RG:ks
Enclosures



An Equal Opportunity Employer M/F/D

SPECIAL NOTES FOR PCC PATCHING

I. DESCRIPTION

Except as specified herein, perform all work in accordance with the Department's 2008 Standard Specifications, and applicable interim Supplemental Specifications, Special Provisions and Special Notes, and Standard and Sepia Drawings, current editions. Take note that Special Provision 76 is not applicable to this project. Furnish all materials, labor, equipment, and incidentals for the following work:

(1) Remove and replace PCC Pavement at the locations listed and/or as directed by the Engineer; (2) Maintain and Control Traffic; and (3) All other work specified as part of this contract.

II. MATERIALS

The Department will sample and test all materials according to Department's Sampling Manual. Make the materials available for sampling a sufficient time in advance of the use of the materials to allow for the necessary time for testing, unless otherwise specified in these notes.

A. Maintain and Control Traffic. See Traffic Control Plan.

B. Dense Graded Aggregate. Contrary to Special Note for Full Depth Concrete Pavement Repair, use DGA; do not use Crushed Stone Base in lieu of DGA.

C. Portland Cement Concrete Pavement. Use non-reinforced JPC Pavement/24 for full depth replacement of concrete pavement meeting the requirements of the Special Note for Full Depth Concrete Pavement Repair. At the Contractor's option, with no additional cost to the Department, use other high early strength rapid setting concrete; however, obtain the Engineer's approval prior to use. Do not use chloride accelerators. Furnish all other materials according to the Standard Specifications or Special Note for Full Depth Concrete Pavement Repair, as applicable..

D. Pavement Markings. See Traffic Control Plan.

E. Joint and Crack Sealing. See Special Note for Full Depth Concrete Pavement Repair.

III. CONSTRUCTION METHODS

A. Maintain and Control Traffic. See Traffic Control Plan.

B. Site Preparation. Be responsible for all site preparation, including but not limited to, incidental excavation and backfilling; removal of all obstructions or any other items; disposal of waste materials, sweeping and removal of debris; temporary and permanent erosion and water pollution control; restoration; and any other incidentals. Perform all site preparation operations only as approved or directed by the Engineer.

C. Concrete Pavement Removal and Replacement. Except as specified in these notes, remove and replace full depth concrete pavement in accordance with Special Note for Full Depth Concrete Pavement Repair. Removal locations and dimensions listed in the summaries are approximate only; the Engineer will determine actual locations and dimensions at the time of construction. The Engineer may add additional locations within the project limits at any time prior to completion. Contrary to the Special Note for Full Depth Concrete Pavement Repair, the Engineer may designate non-standard distances from the joint to be used. Remove pavement according to Special Note for Full Depth Concrete Pavement Repair by a saw cut and lift method without unnecessarily disturbing the underlying base. Double sawing of large slab removal limits will be allowed to facilitate removal. Place PCC Pavement with nominal depth of 10 inches; however, transition the finished grade of the PCC Pavement to match the adjacent pavement that is to remain in place; therefore, the actual thickness of the pavement may be greater than existing in some areas. Install tie and dowel bars according to Special Note for Full Depth Concrete Pavement Repair using gang drills, capable of drilling a minimum of four holes at a time. Perform concrete pavement removal and replacement in such a manner that removal and replacement are accomplished on the same day at each location. Once the removal of pavement has begun, work continuously until the new PCC Pavement is placed to eliminate the hole. The Engineer will allow hand finishing; however, perform initial strike-off with a rotary drum screed. Contrary to Section 501.03.13, do not texture by the formation of transverse grooves. All other applicable sections of Special Note for Full Depth Concrete Pavement Repair shall apply except as specified herein.

Surface tolerances will be verified by straightedge and strictly enforced.

D. Partial Depth Patching. See Special Note for Partial Depth Patching.

E. Joint and Crack Sealing. Seal joints in the new PCC pavement according to Special Note for Full Depth Concrete Pavement Repair.

F. Disposal of Waste. Dispose of all removed concrete, asphalt materials, debris, excess excavation, and other waste off the right-of-way at approved sites obtained by the Contractor at no additional cost to the Department. See Special Note for waste and Borrow.

G. Final Dressing, Clean Up, and Seeding and Protection. See Special Note for Erosion Control.

H. Restoration. Restore any roadway features or private property disturbed by the work or the Contractor's operations in like kind materials and design as directed by the Engineer at no additional cost to the Department or the owner.

I. Pavement Striping. See Traffic Control Plan.

J. On-Site Inspection. Make a thorough inspection of the site prior to submitting a bid and become thoroughly familiar with existing conditions so that the work can be expeditiously performed after a contract is awarded. The Department will consider submission of a bid as evidence of this inspection having been made. The Department will not consider any claims for money or grant time extension resulting from site conditions.

IV. METHOD OF MEASUREMENT

A. Maintain and Control Traffic. See Traffic Control Plan.

B. Site Preparation. Other than the bid items listed, the Department will not measure site preparation will for direct payment, but shall be incidental to the other items of the work.

C. Remove PCC Pavement. See Special Note for Full Depth Concrete Pavement Repair.

D. JPC Pavement/24. See Special Note for Full Depth Concrete Pavement Repair.

E. Partial Depth Patching. See Special Note for Partial Depth Patching.

F. Smooth Dowels and Deformed Tie Bars. See Special Note for Full Depth Concrete Pavement Repair.

G. Joint and Crack Sealing. For joints in new pavement, see Special Note for Full Depth Concrete Pavement Repair. The Department will measure joints and random cracks sealed in existing pavement in linear feet.

H. Pavement Striping. See Traffic Control Plan.

V. BASIS OF PAYMENT

The Department will not make direct payment, other than for the bid items listed. The Department will consider all other items required to complete the construction as incidental to the bid items listed.

A. Maintain and Control Traffic. See Traffic Control Plan.

B. Remove Cement Concrete Pavement. See Special Note for Full Depth Concrete Pavement Repair.

C. JPC Pavement/24. See Special Note for Full Depth Concrete Pavement Repair.

D. Partial Depth Patching. See Special Note for Partial Depth Patching.

SPECIAL NOTE FOR FULL DEPTH CONCRETE PAVEMENT REPAIR

This Special Note applies to full depth repairs of concrete pavement. This note supersedes Special Provision 76 in the 2008 Standard Specifications. Section references herein are to the Department's 2008 Standard Specifications for Road and Bridge Construction.

1.0 DESCRIPTION. Remove and replace concrete pavement. Comply with the applicable Standard Drawings and the Standard Specifications except as specifically superseded herein.

2.0 MATERIALS AND EQUIPMENT.

2.1 JPC Pavement. Test concrete materials according to section 601.03.03. Conform to 501, 502, and 601 except that the concrete must achieve 3000 psi in accordance with Section 4.4 of this note. The Engineer may allow pavement to be opened to traffic at less than 3,000 psi subject to the deductions described in Section 4.4 of this note.

2.2 Dowel Bars and Sleeves. Conform to 811

2.3 Tie Bars. Conform to Section 811. Use epoxy coated tie bars in longitudinal and transverse joints.

2.4 Joint Sealants. Conform to Subsection 807.03.01 or 807.03.05.

2.5 Grout Adhesives and Epoxy Resin Systems. Conform to Section 826.

2.6 Dense Graded Aggregate (DGA) and Crushed Stone Base (CSB). Conform to Section 805.

2.7 Geotextile Fabric. Conform to Section 843.

2.8 Drills. Drill holes using a gang drill, capable of drilling a minimum of four simultaneously. Misalignment of holes shall not exceed 1/4 inch in the vertical or oblique plane.

2.9 Hammers. Only use chisel point hammers weighing less than 40 pounds to remove deteriorated concrete.

3.0 CONSTRUCTION.

3.1 Removal of Existing Pavement. Remove existing pavement to the extent the Contract specifies or as the Engineer directs. The minimum length of patches measured along centerline is 3 feet on each side of an existing joint.

When working with pavements with non-skewed transverse joints, if it is necessary to remove existing pavement closer than 6 feet to a transverse joint, remove the pavement 3 feet beyond that joint .

When working with pavements with skewed transverse joints, if it is necessary to remove existing pavement closer than 3 feet to a transverse joint, remove the

pavement 3 feet beyond that joint.

Details of configurations of pavement and joints for various situations are depicted in the drawings herein.

When small areas of removal and replacement are performed at bridge ends, maintain or reconstruct existing expansion joints at their existing location. When the Engineer determines extensive full width removal and replacement is required, construct new expansion joints at the locations shown on Standard Drawing No. RPN-010.

In the removal operation, make a full depth saw cut longitudinally along the centerline joint and shoulder joint and transversely along the area marked for removal. To prevent damage to the subbase, do not allow the saw to penetrate more than ½" into the subbase. The Engineer may direct or approve additional cuts within the removal area for ease of removal of the damaged slab and to prevent damage to adjacent pavement to remain in place. Do not overcut beyond the limits of the removal area. Prevent saw slurry from entering existing joints and cracks. To avoid pumping and erosion beneath the slab, do not allow traffic on sawed pavement for more than 48 hours before beginning removal procedures, unless directed by the Engineer.

Lift out the deteriorated concrete vertically with lift pins. If approved by the Engineer, use other methods that do not damage the base, shoulder, or sides of pavement that is to be left in place. If any damage does occur, repair as the Engineer directs and use an acceptable alternative method for the removal process. Do not damage the pavement base during these operations.

3.2 Pavement Replacement. Do not damage the pavement base during these operations.

3.2.1 Preparation of Base. Compact the new and existing aggregate base to the Engineer's satisfaction. The Engineer will accept compaction by either visual inspection or by nuclear gauge. When the Engineer deems it necessary to stabilize the existing base or replace unsuitable materials, excluding bridge ends, use 12 inches of geotextile fabric wrapped No. 2 aggregate topped with 4 inches of DGA or CSB. Use either Type III or Type IV geotextile fabric. Flowable fill and cement stabilization may be used as an alternative to stabilize the existing base or to replace unsuitable materials when a plan for such is presented to and approved by the Engineer. The Engineer may also direct using only DGA or CSB to correct base deficiencies. At bridge ends, treat existing base and subgrade as the Contract specifies. During compaction, wet the base as the Engineer directs. Compact areas not accessible to compaction equipment by hand tamping.

3.2.2 Underdrains. Construct, or repair damage to, pavement edge drains according to Section 704. If underdrains are placed omitting areas to be patched, construct additional lateral drains as necessary to provide outlets for the installed underdrain until performing the pavement replacement and completing the underdrain system. Provide drainage for any undercut or base repair areas.

3.2.3 Pavement Replacement. Using load transfer assemblies for dowel joints drill into the existing slab according to the details shown herein and on the Standard Drawings.

Use plain epoxy coated dowels of the size specified on the standard

drawings based on the pavement thickness for contraction and expansion joints.

Drill holes for dowel bars and tie bars into the face of the existing slab, at a diameter as specified in the following. Drill the dowel bar holes and tie bar holes to a depth equal to 1/2 the length of the bars. Anchor tie bars into the existing pavement using an epoxy resin. Anchor dowel bars into the existing pavement using either an epoxy resin or an adhesive grout. For tie bars and dowel bars where an epoxy resin is to be used drill the holes 1/8 inch larger than the bar diameter. For dowel bars where an adhesive grout product is to be used, drill holes 1/4 inch larger than the bar diameter. Use a clear or opaque grout retention disk in both grout and epoxy applications. Operate the equipment to prevent damage to the pavement being drilled. Obtain the Engineer's approval of the drilling procedure. Install load transfer assemblies according to the Standard Drawings and Standard Specifications.

When indicated herein or in the Standard Drawings, use 1 inch deformed tie bars, 18 inches long on 30-inch centers and starting and ending 20 inches inside the edges of the repair area in the longitudinal joint. Use 1 inch deformed tie bars, or plain epoxy coated dowel bars sized in accordance with the Standard Drawings, 18 inches long beginning 12 inches inside of each edge and on 12-inch centers in transverse construction joints.

Install the dowels and tie bars according to Section 511 unless contradicted here. Ensure the holes are dry and free of dust and debris. Use a nozzle to insert the grout or epoxy starting at the back of the drilled hole to allow for full coating of the dowel or tie bar. After placement, use a bond breaker on the section of the dowel bar that is protruding from the hole.

Mix, place, finish, and cure concrete according to Section 501 with the exception that the Department will allow truck mixing, 2-bag mixers, and hand finishing.

When required, use a form on the side of the slab at longitudinal joints. When the adjacent traffic lane is not closed to traffic or the drop-off is not protected, temporarily fill the space between the form and the adjacent pavement with DGA. After placing the slab, remove the DGA and form. Fill the hole with concrete and thoroughly consolidate by rodding, spading, and sufficient vibration to form a dense homogeneous mass. Use a form on the side of the slab adjacent to shoulders. Excavate and backfill as shown on Section F'-F'.

For patches less than 25 feet in length, use a bond breaker and do not install tie bars at the longitudinal joint. Bond breakers should not exceed 1/8 inch in thickness, e.g. tar paper.

When resurfacing is required, a float finish is satisfactory. Otherwise, broom finish or, when the adjacent surface has a grooved finish, texture the surface according to Subsection 501.03.13 H). Finish the surface, including joints, to meet a surface tolerance of 1/8 inch in 10 feet that will be verified by straightedge. Cure the pavement and apply curing membranes according to 501.03.15.

Keep all pavement surfaces adjacent to this operation reasonably clean of excess grout and other materials at all times. Maintain all original longitudinal joints. Place transverse joints according to the details shown herein and on the Standard Drawings.

3.3 Joint Sealing. Seal all new or partially new joints with silicone rubber sealant or hot-poured elastic joint sealant according to Subsection 501.03.18.

4.0 MEASUREMENT.

4.1 Remove JPC Pavement. The Department will measure the quantity in square yards of surface area. The Department will not measure removal of underlying base material for payment and will consider it incidental to Remove JPC Pavement.

4.2 DGA or CSB. The Department will measure the quantity used to stabilize the existing base or to replace unsuitable material in tons. The Department will not measure removal of existing base material or underlying material for payment and will consider incidental to DGA or CSB. The quantity of DGA used for the drop-off protection shall be incidental to this work and will not be measured for payment.

4.3 JPC Pavement Non-Reinforced. The Department will measure according to 501.04.01. The Department will not measure dowels, tie bars, , or joint sealing for payment and will consider it incidental to Non-Reinforced JPC Pavement.

JPC Pavement will be paid according to section 5.0 below and according to the following payment schedule based on the compressive strength. The cylinders for payment will be tested two hours prior the scheduled opening of traffic.

3000 psi and up	100% payment
2750 to 3000 psi	75% payment and approval from the Engineer to open to traffic*
2500 to 2750 psi	50% payment and approval from the Engineer to open to traffic*
2250 to 2500 psi	25% payment and approval from the Engineer to open to traffic*
Below 2250 psi	10% payment and no potential to open to traffic. Maintain traffic closure until concrete reaches a minimum of 2250 psi.

*If the Engineer approves opening to traffic, the Engineer will evaluate the concrete at 28 days (or sooner) to determine if the removal and replacement of the concrete is necessary due to pavement distress induced by the early opening (i.e. noticeable cracking). If required by the Engineer, remove and replace those slabs showing distress at no cost to the Department.

4.5 Underdrains. The Department will measure the quantity according to Subsection 704.04. The Department will not measure lateral drains for payment and will consider them incidental to the Underdrains.

5.0 PAYMENT. The Department will make payment for the completed and accepted quantities under the following:

<u>Code</u>	<u>Pay Item</u>	<u>Pay Unit</u>
----	Remove JPC Pavement	Square Yard
00001	DGA Base	Ton
00003	Crushed Stone Base	Ton
02069-02071, 02073, 02075, 02084, 02086, 02088	JPC Pavement Non-Reinforced, thickness	See Subsection 501.05
01000	Perforated Pipe, 4-inch	Linear Foot
02598, 02599	Fabric-Geotextile, Type	Square Yard

The Department will consider payment as full compensation for all work required in this provision.

September 9, 2010

1. SAW AT LOCATIONS "J" AND ALONG LONGITUDINAL JOINT (IF ONLY ONE LANE IS REMOVED) FULL DEPTH WITHOUT DAMAGE TO EXISTING CONCRETE. SAW RELIEF JOINTS AS THE ENGINEER DIRECTS OR APPROVES. REMOVE THE EXISTING JPC PAVEMENT TO THE LENGTH AND AT THE LOCATIONS NOTED ELSEWHERE IN THE CONTRACT. L=6 FEET MINIMUM AND LOCATIONS "J" SHALL NOT BE CLOSER THAN 6 FEET TO ANY TRANSVERSE JOINT BEYOND THE REPAIR.
2. INSTALL SMOOTH, LOAD TRANSFER DOWELS (EXCEPT USE TIE BARS FOR SECTION C), 18 INCHES LONG (SEE STANDARD DRAWING NO. RPS-020 FOR DOWEL SIZE) AT LOCATIONS "J". INSTALL DOWELS (OR TIE BARS FOR SECTION C) IN THE EXISTING CONCRETE USING EPOXY TYPE IV. INSTALL DOWELS (OR TIE BARS FOR SECTION C) ON 12 INCH CENTERS BEGINNING 12 INCHES FROM THE EDGE OF THE SLAB. IF L IS GREATER THAN 20 FEET, INSTALL NEW LOAD TRANSFER ASSEMBLY(S) AND CONSTRUCT CONTRACTION JOINTS SUCH THAT THE DISTANCE BETWEEN JOINTS IN THE REPLACED SECTION IS NO LESS THAN 10 FEET OR MORE THAN 20 FEET. TRANSVERSE JOINTS SHALL BE SPACED APPROXIMATELY 15' EQUIDISTANT, BUT NOT LESS THAN 10 FEET OR NO MORE THAN 20 FEET. ADJUST JOINTS TO PROVIDE THE MINIMUM NUMBER OF JOINTS WITHOUT EXCEEDING THE 10-20 FOOT RANGE. INSTALL NEW LOAD TRANSFER ASSEMBLY(S) AND ALIGN LOAD TRANSFER ASSEMBLY(S) WITH AN EXISTING JOINT OR CRACK IN THE ADJACENT SLAB IF ONLY ONE LANE IS BEING REPLACED.
3. IF ONLY ONE LANE IS REMOVED, AND L > 25', INSTALL NEW 1-INCH TIE BARS 18 INCHES LONG ON 30 INCH CENTERS IN THE LONGITUDINAL JOINT USING EPOXY TYPE IV. IF 2 OR MORE LANES ARE REMOVED, CONSTRUCT LONGITUDINAL JOINT(S) ACCORDING TO THE STANDARD DRAWING EXCEPT USE 1-INCH TIE BARS 18 INCHES LONG ON 30 INCH CENTERS. IF L > 25', DO NOT TIE THE LONGITUDINAL JOINT TO THE EXISTING LANE; USE A BOND BREAKER MATERIAL APPROVED BY THE ENGINEER THAT WILL ASSURE NO INTERACTION WITH THE ADJACENT LANE.
4. REPLACE WITH NON-REINFORCED JPC PAVEMENT AND INSTALL CONTRACTION JOINTS AT LOCATIONS "K" AND CONTRACTION JOINTS (OR A CONSTRUCTION JOINT FOR LOCATION C) AT LOCATIONS "J". SAW AND SEAL ALL JOINTS.
6. SEE "CROSS SECTION" FOR SECTION F.

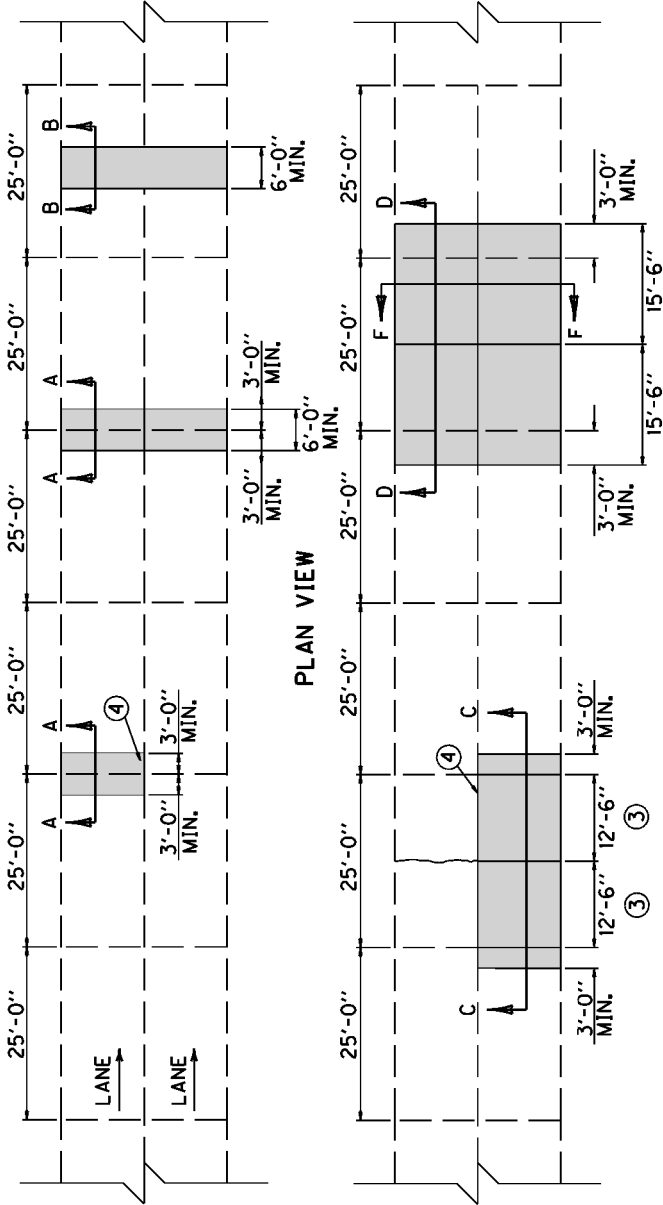

PLAN VIEW

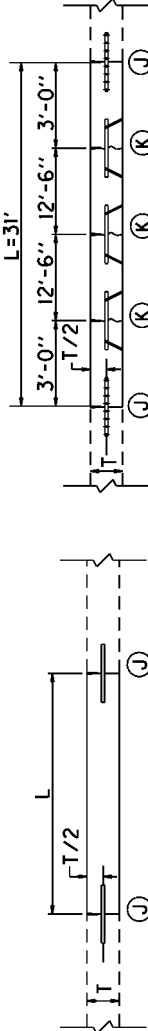

SECTION A
JOINT REPLACEMENT

SECTION C

LANE REPLACEMENT WHERE ADJACENT LANES OR JPC SHOULDERS WILL REMAIN

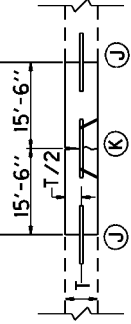
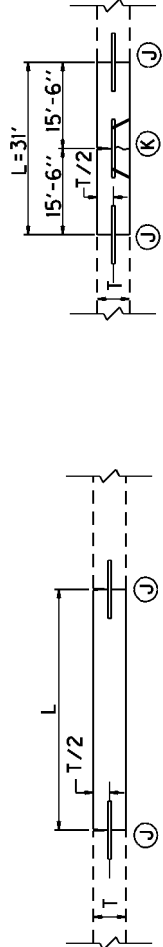

KENTUCKY DEPARTMENT OF HIGHWAYS
25' JOINT SPACING
APPROVED _____ DATE _____ TECHNICAL DIVISION OF DESIGN

1. SAW AT LOCATIONS "J" AND ALONG LONGITUDINAL JOINT (IF ONLY ONE LANE IS REMOVED) FULL DEPTH WITHOUT DAMAGE TO EXISTING CONCRETE. SAW RELIEF JOINTS AS THE ENGINEER DIRECTS OR APPROVES. REMOVE THE EXISTING JPC PAVEMENT TO THE LENGTH AND AT THE LOCATIONS NOTED ELSEWHERE IN THE CONTRACT. L=6 FEET MINIMUM AND LOCATIONS "J" SHALL NOT BE CLOSER THAN 6 FEET TO ANY TRANSVERSE JOINT BEYOND THE REPAIR.
2. INSTALL SMOOTH, LOAD TRANSFER DOWELS (EXCEPT USE TIE BARS FOR SECTION CC, 18 INCHES LONG (SEE STANDARD DRAWING NO. RPS-020 FOR DOWEL SIZE) AT LOCATIONS "J". INSTALL DOWELS OR TIE BARS FOR SECTION CC) IN THE EXISTING CONCRETE USING EPOXY TYPE IV. INSTALL DOWELS OR TIE BARS FOR SECTION CC) ON 12 INCH CENTERS BEGINNING 12 INCHES FROM THE EDGE OF THE SLAB.
3. IF L IS GREATER THAN 20 FEET, INSTALL NEW LOAD TRANSFER ASSEMBLY(S) AND CONSTRUCT CONTRACTION JOINTS SUCH THAT THE DISTANCE BETWEEN JOINTS IN THE REPLACED SECTION IS NO LESS THAN 10 FEET OR MORE THAN 20 FEET. TRANSVERSE JOINTS SHALL BE SPACED APPROXIMATELY 15' EQUIDISTANT, BUT NOT LESS THAN 10 FEET OR NO MORE THAN 20 FEET. ADJUST JOINTS TO PROVIDE THE MINIMUM NUMBER OF JOINTS WITHOUT EXCEEDING THE 10-20 FOOT RANGE. INSTALL NEW LOAD TRANSFER ASSEMBLY(S) AND ALIGN LOAD TRANSFER ASSEMBLY(S) WITH AN EXISTING JOINT OR CRACK IN THE ADJACENT SLAB IF ONLY ONE LANE IS BEING REPLACED.
4. IF ONLY ONE LANE IS REMOVED, AND L>25', INSTALL NEW 1-INCH TIE BARS 18 INCHES LONG ON 30 INCH CENTERS IN THE LONGITUDINAL JOINT USING EPOXY TYPE IV. IF 2 OR MORE LANES ARE REMOVED, CONSTRUCT LONGITUDINAL JOINT(S) ACCORDING TO THE STANDARD DRAWING EXCEPT USE 1-INCH TIE BARS 18 INCHES LONG ON 30 INCH CENTERS. IF L<25', DO NOT TIE THE LONGITUDINAL JOINT TO THE EXISTING LANE; USE A BOND BREAKER MATERIAL APPROVED BY THE ENGINEER THAT WILL ASSURE NO INTERACTION WITH THE ADJACENT LANE.
5. REPLACE WITH NON-REINFORCED JPC PAVEMENT AND INSTALL CONTRACTION JOINTS AT LOCATIONS "K" AND CONTRACTION JOINTS FOR A CONSTRUCTION JOINT FOR LOCATION CC) AT LOCATIONS "J". SAW AND SEAL ALL JOINTS.
6. SEE "CROSS SECTION" FOR SECTION F.

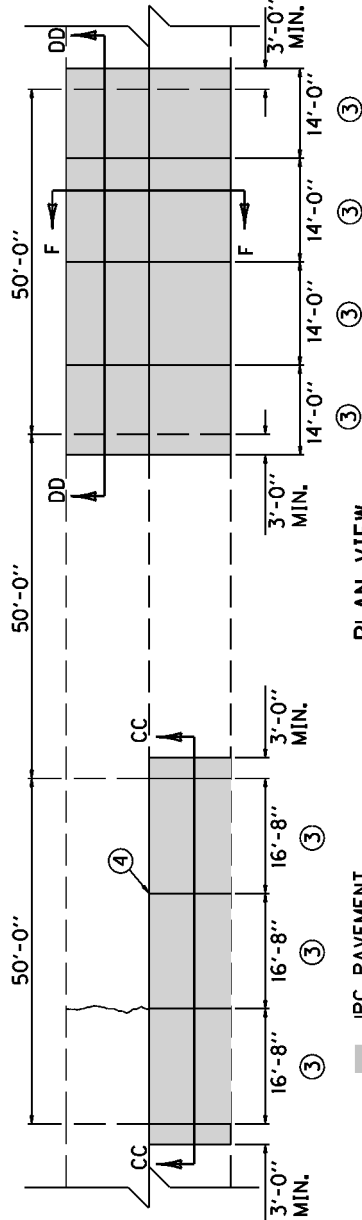
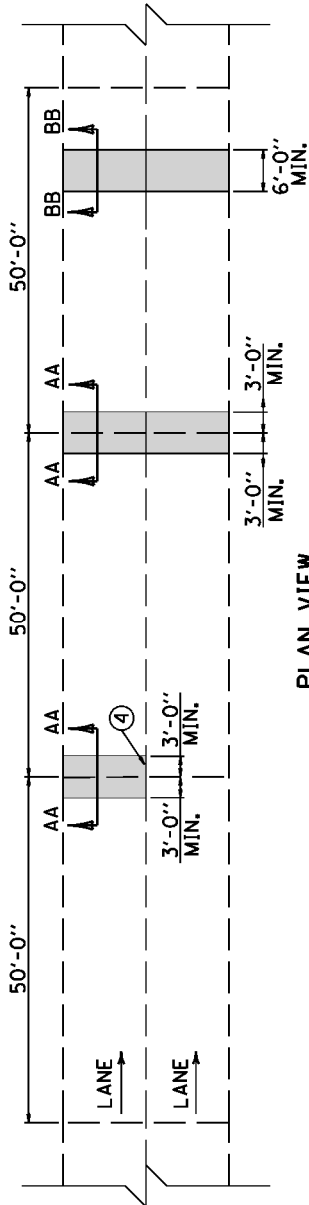

JPC PAVEMENT TO BE REMOVED

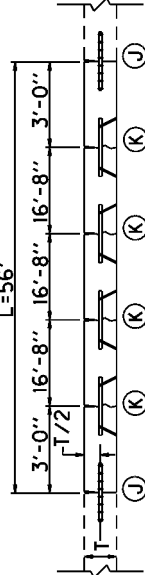

SECTION AA
 JOINT REPLACEMENT

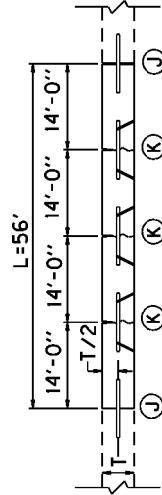
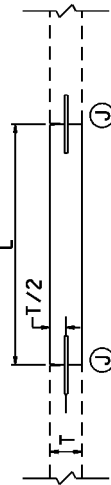

SECTION BB
 MID-SLAB REPLACEMENT

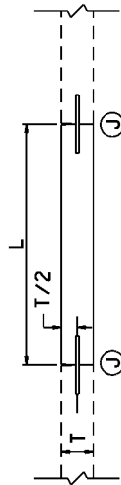

KENTUCKY DEPARTMENT OF HIGHWAYS
50' JOINT SPACING
SUBMITTED: _____ DATE _____

1. SAW AT LOCATIONS "J" AND ALONG LONGITUDINAL JOINT (IF ONLY ONE LANE IS REMOVED) FULL DEPTH WITHOUT DAMAGE TO EXISTING CONCRETE. SAW RELIEF JOINTS AS THE ENGINEER DIRECTS OR APPROVES. REMOVE THE EXISTING JPC PAVEMENT TO THE LENGTH AND AT THE LOCATIONS NOTED ELSEWHERE IN THE CONTRACT. L=6 FEET MINIMUM AND LOCATIONS "J" SHALL NOT BE CLOSER THAN 6 FEET TO ANY TRANSVERSE JOINT BEYOND THE REPAIR.
2. INSTALL SMOOTH, LOAD TRANSFER DOWELS (EXCEPT USE TIE BARS FOR SECTION DDD), 18 INCHES LONG. (SEE STANDARD DRAWING NO. RPS-020 FOR DOWEL SIZE) AT LOCATIONS "J". INSTALL DOWELS (OR TIE BARS FOR SECTION DDD) IN THE EXISTING CONCRETE USING EPOXY TYPE IV. INSTALL DOWELS (OR TIE BARS FOR SECTION DDD) ON 12 INCH CENTERS BEGINNING 12 INCHES FROM THE EDGE OF THE SLAB. IF L IS GREATER THAN 20 FEET, INSTALL NEW LOAD TRANSFER ASSEMBLY(S) AND MATCH EXISTING JOINTS. INSTALL NEW LOAD TRANSFER ASSEMBLY(S) AND ALIGN LOAD TRANSFER ASSEMBLY(S) WITH EXISTING JOINTS IN ADJACENT SLABS.
- ④ IF ONLY ONE LANE IS REMOVED, AND L > 25', INSTALL NEW 1-INCH TIE BARS 18 INCHES LONG ON 30 INCH CENTERS IN THE LONGITUDINAL JOINT USING EPOXY TYPE IV. IF 2 OR MORE LANES ARE REMOVED, CONSTRUCT LONGITUDINAL JOINT(S) ACCORDING TO THE STANDARD DRAWING EXCEPT USE 1-INCH TIE BARS 18 INCHES LONG ON 30 INCH CENTERS. IF L > 25', DO NOT TIE THE LONGITUDINAL JOINT TO THE EXISTING LANE; USE A BOND BREAKER MATERIAL APPROVED BY THE ENGINEER THAT WILL ASSURE NO INTERACTION WITH THE ADJACENT LANE.
5. REPLACE WITH NON-REINFORCED JPC PAVEMENT AND INSTALL CONTRACTION JOINTS AT LOCATIONS "K" AND CONTRACTION JOINTS (OR A CONSTRUCTION JOINT FOR LOCATION DDD) AT LOCATIONS "J". SAW AND SEAL ALL JOINTS.
6. SEE "CROSS SECTION" FOR SECTION F.

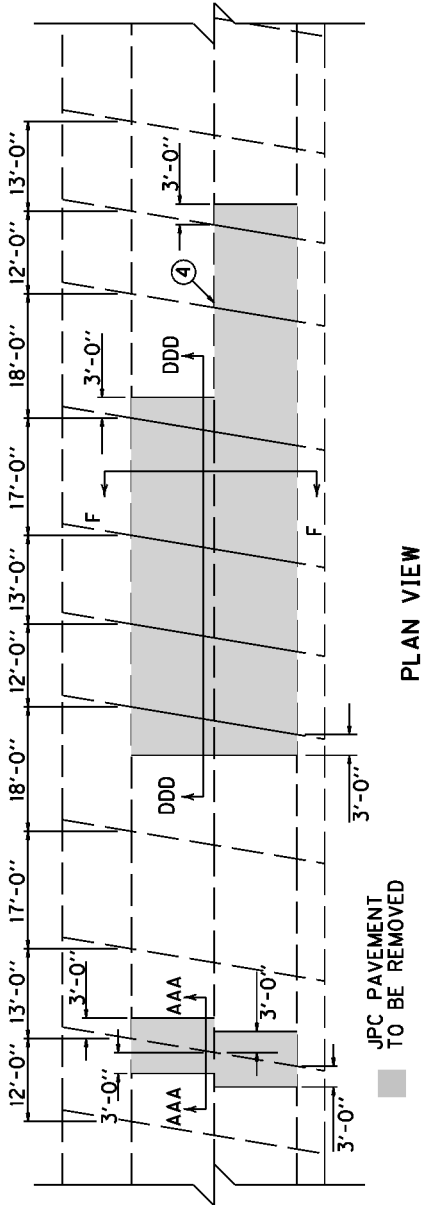

PLAN VIEW

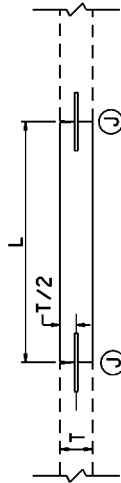

SECTION AAA
JOINT REPLACEMENT

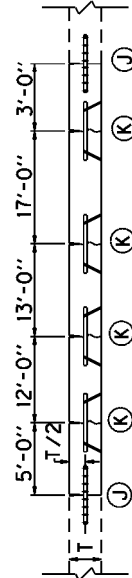

SECTION DDD
LANE REPLACEMENT
(ALWAYS MATCH EXISTING JOINTS)

KENTUCKY DEPARTMENT OF HIGHWAYS
RANDOM SKEWED
APPROVED _____ DATE _____ TECHNICAL DIVISION OF DESIGN

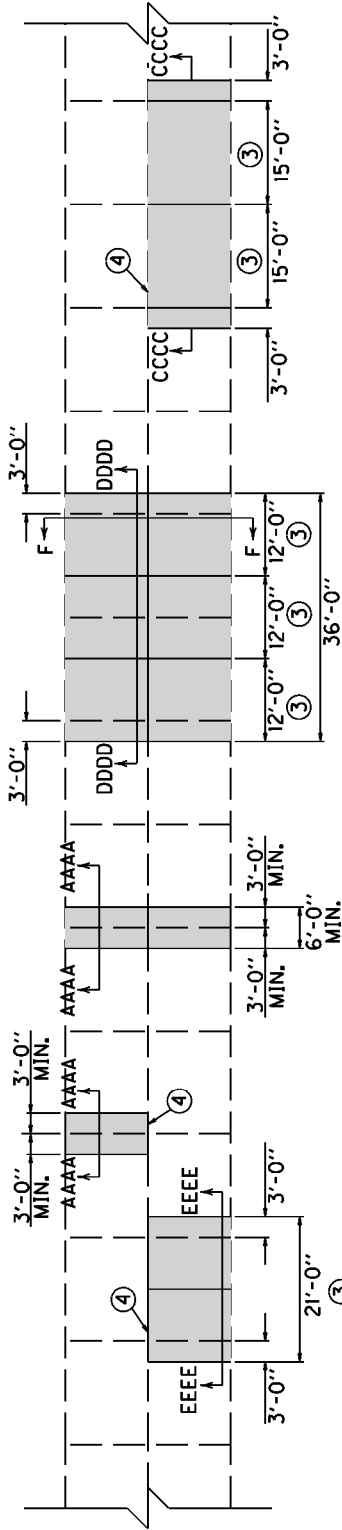

PLAN VIEW

1. SAW AT LOCATIONS "J" AND ALONG LONGITUDINAL JOINT (IF ONLY ONE LANE IS REMOVED) FULL DEPTH WITHOUT DAMAGE TO EXISTING CONCRETE; SAW RELIEF JOINTS AS THE ENGINEER DIRECTS OR APPROVES. REMOVE THE EXISTING JPC PAVEMENT TO THE LENGTH AND AT THE LOCATIONS NOTED ELSEWHERE IN THE CONTRACT. L=6 FEET MINIMUM AND LOCATIONS "J" SHALL NOT BE CLOSER THAN 6 FEET TO ANY TRANSVERSE JOINT BEYOND THE REPAIR.
2. INSTALL SMOOTH, LOAD TRANSFER DOWELS (EXCEPT USE TIE BARS FOR SECTION CCCC); 18 INCHES LONG (SEE STANDARD DRAWING NO. RPS-020 FOR DOWEL SIZE) AT LOCATIONS "J". INSTALL DOWELS (OR TIE BARS FOR SECTION CCCC) IN THE EXISTING CONCRETE USING EPOXY TYPE IV. INSTALL DOWELS OR TIE BARS FOR SECTION CCCC ON 12 INCH CENTERS BEGINNING 12 INCHES FROM THE EDGE OF THE SLAB.
3. IF L IS GREATER THAN 20 FEET, INSTALL NEW LOAD TRANSFER ASSEMBLY(S) AND CONSTRUCT CONTRACTION JOINTS SUCH THAT THE DISTANCE BETWEEN JOINTS IN THE REPLACED SECTION IS NO LESS THAN 10 FEET OR MORE THAN 20 FEET. TRANSVERSE JOINTS SHALL BE SPACED APPROXIMATELY 15' EQUIDISTANT, BUT NOT LESS THAN 10 FEET OR NO MORE THAN 20 FEET. ADJUST JOINTS TO PROVIDE THE MINIMUM NUMBER OF JOINTS WITHOUT EXCEEDING THE 10-20 FOOT RANGE. INSTALL NEW LOAD TRANSFER ASSEMBLY(S) AND ALIGN LOAD TRANSFER ASSEMBLY(S) WITH AN EXISTING JOINT OR CRACK IN THE ADJACENT SLAB IF ONLY ONE LANE IS BEING REPLACED.
4. IF ONLY ONE LANE IS REMOVED, AND L > 25', INSTALL NEW 1-INCH TIE BARS 18 INCHES LONG ON 30 INCH CENTERS IN THE LONGITUDINAL JOINT USING EPOXY TYPE IV. IF 2 OR MORE LANES ARE REMOVED, CONSTRUCT LONGITUDINAL JOINT(S) ACCORDING TO THE STANDARD DRAWING EXCEPT USE 1-INCH TIE BARS 18 INCHES LONG ON 30 INCH CENTERS. IF L > 25', DO NOT TIE THE LONGITUDINAL JOINT TO THE EXISTING LANE; USE A BOND BREAKER MATERIAL APPROVED BY THE ENGINEER THAT WILL ASSURE NO INTERACTION WITH THE ADJACENT LANE.
5. REPLACE WITH NON-REINFORCED JPC PAVEMENT AND INSTALL CONTRACTION JOINTS AT LOCATIONS "K" AND CONTRACTION JOINTS (OR A CONTRACTION JOINT FOR LOCATION CCCC) AT LOCATIONS "J". SAW AND SEAL ALL JOINTS.
6. SEE "CROSS SECTION" FOR SECTION F.

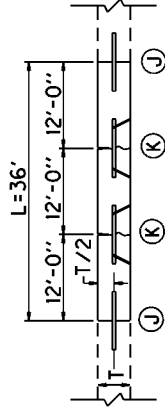

SECTION DDDD
FULL WIDTH REPLACEMENT
(INCLUDING JPC SHOULDERS)

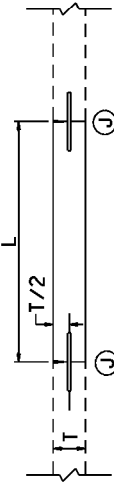

SECTION AAAA
JOINT REPLACEMENT

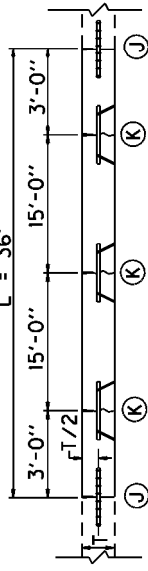

SECTION CCCC
LANE REPLACEMENT WHERE ADJACENT LANES OR JPC SHOULDERS WILL REMAIN

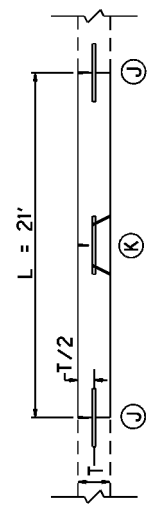

SECTION EEEE
LANE REPLACEMENT L < 25'

KENTUCKY
DEPARTMENT OF HIGHWAYS
15' JOINT SPACING
APPROVED _____ DATE _____ TERM DIVISION OF DESIGN

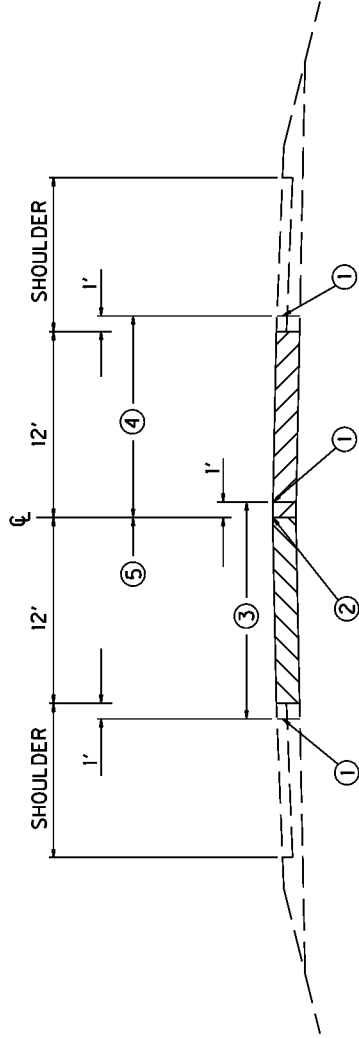

SECTION F

- ① SAW-CUT LINE. THIS ONE FOOT IS TO ALLOW FOR A FORM AND THE REMOVAL AND REPLACEMENT SHALL BE INCIDENTAL TO THE WORK, EXCEPT NEW ASPHALT MIXTURE SHALL BE PAID DIRECT ON A TONNAGE BASIS, AND NEW JPC PAVEMENT WILL BE PAID BY THE SQUARE YARD. COMPACT THE DGA BASE BY MECHANICAL TAMPERS TO THE ENGINEER'S SATISFACTION.
- ② EXISTING LONGITUDINAL JOINT.
- ③ FIRST SLAB REMOVAL LIMITS AND REPLACE 12-FOOT LANE.
- ④ SECOND SLAB REMOVAL LIMITS AND REPLACE 12-FOOT LANE.
- ⑤ THIS ONE FOOT IS TO ALLOW FOR A FORM ON THE FIRST POUR, AND A TEMPORARY PAVEMENT IS REQUIRED. THE DEPARTMENT WILL NOT REQUIRE REMOVAL OF THIS ONE FOOT IF THE GRADE OF THE EXISTING PAVEMENT IS ADEQUATE TO ENSURE THE NEW CONCRETE CAN BE PLACED AND FINISHED TO THE SATISFACTION OF THE ENGINEER. ANY TEMPORARY PAVEMENT IS INCIDENTAL TO JPC PAVEMENT.
6. THE ABOVE DRAWING DEPICTS THE ORDER OF SLAB REMOVAL WHEN BOTH ARE TO BE REMOVED AT THE SAME LOCATION. WHEN ONLY ONE SLAB OR LANE IS TO BE REMOVED, REMOVE AND REPLACE ACCORDING TO SECTION C, CC, OR CCCC. TRAFFIC CONTROL WILL SPECIFY WHICH LANE TO REMOVE FIRST.

KENTUCKY DEPARTMENT OF HIGHWAYS
CROSS SECTION
APPROVED _____ DATE _____ <small>TECHNICAL DIVISION OF DESIGN</small>

SPECIAL NOTE FOR PARTIAL DEPTH CONCRETE PAVEMENT REPAIR

This Special Note applies to partial depth repairs of concrete pavement. Section references herein are to the Department's 2008 Standard Specifications for Road and Bridge Construction.

1.0 DESCRIPTION. Remove and replace small, shallow areas of deteriorated concrete that extend no deeper than one-third of the slab thickness. Comply with the applicable Standard Drawings and the Standard Specifications except as specifically superseded herein.

2.0 MATERIALS AND EQUIPMENT.

2.1 Rapid Set Concrete Patching Materials. See the List of Approved Materials for Rapid and Very Rapid hardening materials from the Division of Materials.

2.2 Hot-Poured Elastic and Silicone Rubber Sealant. Conform to Subsection 807.03.01 or 807.03.05.

2.3 Hammers. Only use chisel point hammers weighing less than 15 pounds to remove deteriorated concrete.

3.0 CONSTRUCTION.

3.1 Repair Dimension Selection. The locations for partial-depth repair will be identified in the plans or proposal or as specified by the Engineer during construction. Identify the repair boundaries by sounding the concrete with a solid steel rod, a heavy chain, or a ball peen hammer. Repair boundaries should extend a minimum of 3 inches outside unsound areas.

3.2 Concrete Removal. Saw the hole to be patched with a vertical face, to a 2-inch minimum depth and to the configuration the Contract specifies or the Engineer directs. After sawing, keep exposure to traffic to a minimum until patching.

If the area to be patched is deeper than 1/3 the slab depth, construct full depth patches according to the "Special Note for Full-Depth Concrete Pavement Repair". Partial depth patches that become full depth repairs will be paid forty (40) percent of the unit price for Partial Depth Patching.

Keep overcutting beyond the limits of the removed area to a minimum. Prevent saw slurry from entering existing joints and cracks. Clean all saw slurry and other contaminants from overcutting. Repair the overcut area with a low viscosity epoxy compound.

3.3 Repair Area Preparation. Following the removal of the concrete, the surface of the repair area must be prepared to provide a clean, irregular surface for the development of a good bond between the repair material and the existing slab. Clean the repair area by sandblasting followed by compressed airblasting to remove dirt, oil, thin layers of unsound concrete, and laitance. The compressed air used in the final cleaning must be free of oil. This should be checked by placing a cloth over the air compressor nozzle and visually

inspecting for oil.

3.4 Joint Preparation. Partial-depth repairs placed against transverse joints require the use of an insert to act as a bondbreaker or joint reformer. Place the insert so that it prevents intrusion of repair material into the joint opening. Insure the compressible insert extends 1 inch below and 3 inches beyond the repair boundaries. Prior to placement, score the insert at the appropriate depth to accommodate the joint sealant material to be used. Once the patch has cured or set, remove the scored top strip to allow for the joint sealant to be placed.

3.5 Patching Material and Placement.

3.5.1 Rapid Set Concrete Patching Materials. Furnish a repair material specified as “Rapid” or “Very Rapid” hardening listed on the Division of Materials *List of Approved Materials*. A substitute product may be allowed only after submittal and approval by the Division of Materials. Repair materials should be installed according to the manufacturer’s recommendations. All materials used will be tested prior to the project beginning to insure that a minimum opening compressive strength of 3,000 psi can be obtained based on the time requirements listed in the maintenance of traffic notes for the project. No asphaltic based materials will be allowed.

Remove and replace all areas of the patches that display cracks or are not bonded to the underlying pavement.

3.6 Joint Sealing. Seal all new or partially new joints with hot-poured elastic or silicone rubber sealant according to Subsection 501.03.18 D).

4.0 MEASUREMENT.

4.1 Partial Depth Patching. The Department will measure the quantity in cubic feet, either from field measurements or the metered quantity from the mixer, as the Engineer determines.

5.0 PAYMENT. The Department will make payment for the completed and accepted quantities under the following:

<u>Code</u>	<u>Pay Item</u>	<u>Pay Unit</u>
2110	Partial Depth Patching	Cubic Foot

The Department will consider payment as full compensation for all work required in this provision.

Butler COUNTY
FE01 016 9007 034-038
TYPICAL SECTION
MILEPOINTS 34.726-37.126

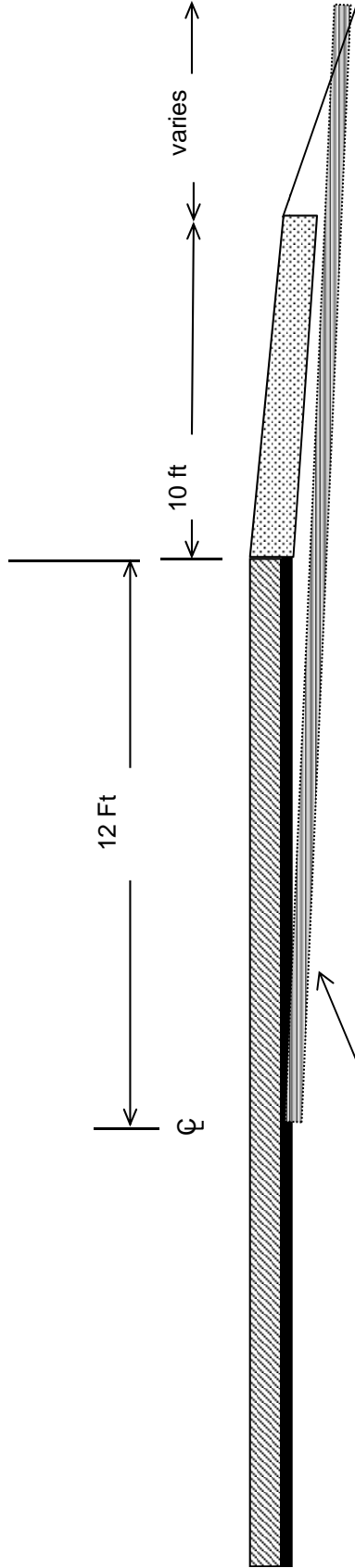

Place 4" Perforated Pipe from the repair area and drain to outside shoulder
As directed by the project engineer

CONTRACT ID: 122326
COUNTY: BUTLER
PROPOSAL: FE01 016 9007 034-038

PAGE: 1
LETTING: 02/24/12
CALL NO: 336

LINE NO	ITEM	DESCRIPTION	APPROXIMATE QUANTITY	UNIT	UNIT PRICE	AMOUNT
SECTION 0001 ROADWAY						
0010	00001	DGA BASE	500.000	TON		
0020	00078	CRUSHED AGGREGATE SIZE NO 2	400.000	TON		
0030	01000	PERFORATED PIPE-4 IN	2,500.000	LF		
0040	01897	ASPHALT WEDGE CURB	400.000	LF		
0050	02014	BARRICADE-TYPE III	8.000	EACH		
0060	02024	JPC PAVEMENT-10 IN/24	1,600.000	SQYD		
0070	02058	REMOVE PCC PAVEMENT	1,600.000	SQYD		
0090	02110	PARTIAL DEPTH PATCHING	150.000	CUFT		
0100	02562	SIGNS	300.000	SQFT		
0110	02599	FABRIC-GEOTEXTILE TYPE IV	2,000.000	SQYD		
0120	02650	MAINTAIN & CONTROL TRAFFIC	(1.00)	LS		
0130	02653	LANE CLOSURE	4.000	EACH		
0140	02775	ARROW PANEL	2.000	EACH		
0150	06515	PAVE STRIPING-PERM PAINT-6 IN	57,024.000	LF		
0160	06592	PAVEMENT MARKER TYPE V-B W/R	100.000	EACH		
0170	06593	PAVEMENT MARKER TYPE V-B Y/R	50.000	EACH		
0180	21173EC	SAW-CLEAN-RESEAL RANDOM CRACKS	400.000	LF		
SECTION 0002 DEMOBILIZATION						
0190	02569	DEMOBILIZATION (AT LEAST 1.5%)		LUMP		
		TOTAL BID				